



DESIGN AND INSTALLATION GUIDE



 **NASAH**[®]
building smarter



CODEMARK™
CMA-CM40172

HEAD OFFICE

Nasahi Building Materials Australia Pty Ltd
1331 Stud Rd, Rowville, Victoria, 3181
P: 1300 2 NASAHI (1300 2 627244)
E: sales@nasahi.net.au

ABOUT NASAHI	5
NASAHI PANELS	6
ADVANTAGES OF NASAHI	7
SYSTEM OVERVIEW	10
STRUCTURAL	12
SYSTEM PERFORMANCE	12
INSTALLATION PROCESS	14
INSTALLATION SEQUENCE	16
WORKING WITH NASAHI PANELS	18
DELIVERY AND HANDLING	19
HEALTH AND SAFETY	20
NCC COMPLIANCE	21
MATERIAL PROPERTIES	23
PANEL REINFORCING LAYOUT	23
DETAILED DRAWINGS	24
WARRANTY & GUARANTEE	35

CONTENTS



NASAHI®
building smarter

www.nasahi.net.au

For the past 20 years Nasahi have been one of the world's largest producers of innovative, high-quality AAC materials. We have become a world leader in the production of revolutionary building materials by investing over AUD\$60 million in the most technologically advanced processes in the industry. Our production facility has the capacity of 700,000 m3 of AAC products per year, selling within China and exporting to Japan, Singapore, Malaysia, Vietnam, Philippines, UAE, Maldives, Russia, Angola, Australia, New Zealand etc. Our reputation for consistently producing high-quality products is exceptional.

The Nasahi range of building systems are regularly tested in Australia by NATA accredited laboratories. They are carefully engineered to comply with the requirements of the Building Code of Australia, and to remain at the cutting edge of product innovation.

Nasahi's in-house engineers provide project specific guidance, assisting with custom projects and bringing your ideas to life.

With warehouses located in every state of Australia, Nasahi can easily meet demands and quickly deliver to site.

Our ISO 9001 and JIS A 5416 manufacturing processes are audited annually by independent authorities. This ensures that we meet the needs of our customers and other stakeholders while complying with statutory and regulatory requirements.

Nasahi's "building smarter" philosophy has integrated the highest quality manufacturing processes with systems in place to meet the demands of the local market. By focusing on service, product quality and technical support we provide a guarantee you can trust.

AUTOCLAVED AERATED CONCRETE (AAC)

Autoclaved Aerated Concrete is a lightweight precast concrete building material that provides excellent structural, thermal, fire, termite and mould-resistance. AAC is manufactured from cement, sand, lime and water; it is aerated by adding an expanding agent to the mix. The mix is poured into a large mould and allowed to rise. These large soft blocks are sliced into the required panel sizes, and are then cured in a steam pressure autoclave for up to 12 hours.

The result is a concrete panel filled with small, finely dispersed air bubbles, which is both strong and lightweight.

An embedded corrosion protected steel mesh inside the panels gives them excellent strength when installed as internal walls or over a load-bearing timber or steel frame. Panels are supplied in a standard width of 600mm and up to 3300mm length, and can easily be cut to size allowing fast and strong installation.

Table 1: Weight of 2200mm Long Panel

Thickness	50mm
Working Panel Weight (650kg/m ³)	43kg

Nasahi Panels are designed to provide a superior wall and floor solution. It's excellent airborne noise transmission properties result in a quieter, more comfortable home at a significantly reduced cost compared with concrete or brick.

Manufactured from lightweight steel-reinforced autoclaved aerated concrete, Nasahi Panels have a working density of 650kg/m³ making them highly resistant to chipping and damage during delivery and handling. Nasahi Panels are also thermally stable, providing long-term durability.

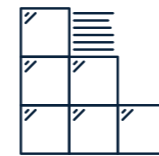

Quick Installation

3 qualified tradespeople can easily install 50m² of Nasahi® Panel per day, making it significantly faster and less labour intensive than traditional masonry.



Lightweight and Strong

Nasahi Panels weigh less than standard concrete masonry, making it convenient, lightweight, and easy to work with. Strength is provided by corrosion protected internal steel reinforcing mesh.



Fire Resistant

Nasahi Panels are deemed non-combustible and are compliant as party walls. Nasahi Panels have been rigorously tested and will provide a FRL of up to 120 minutes.



Quiet

The Nasahi Panel's unique aerated construction provides the thermal performance of a lightweight system while delivering excellent acoustic performance like a dense masonry product.



Transportable

Panels are flat-packed in packs of up to 20 improving transportability to and around site.

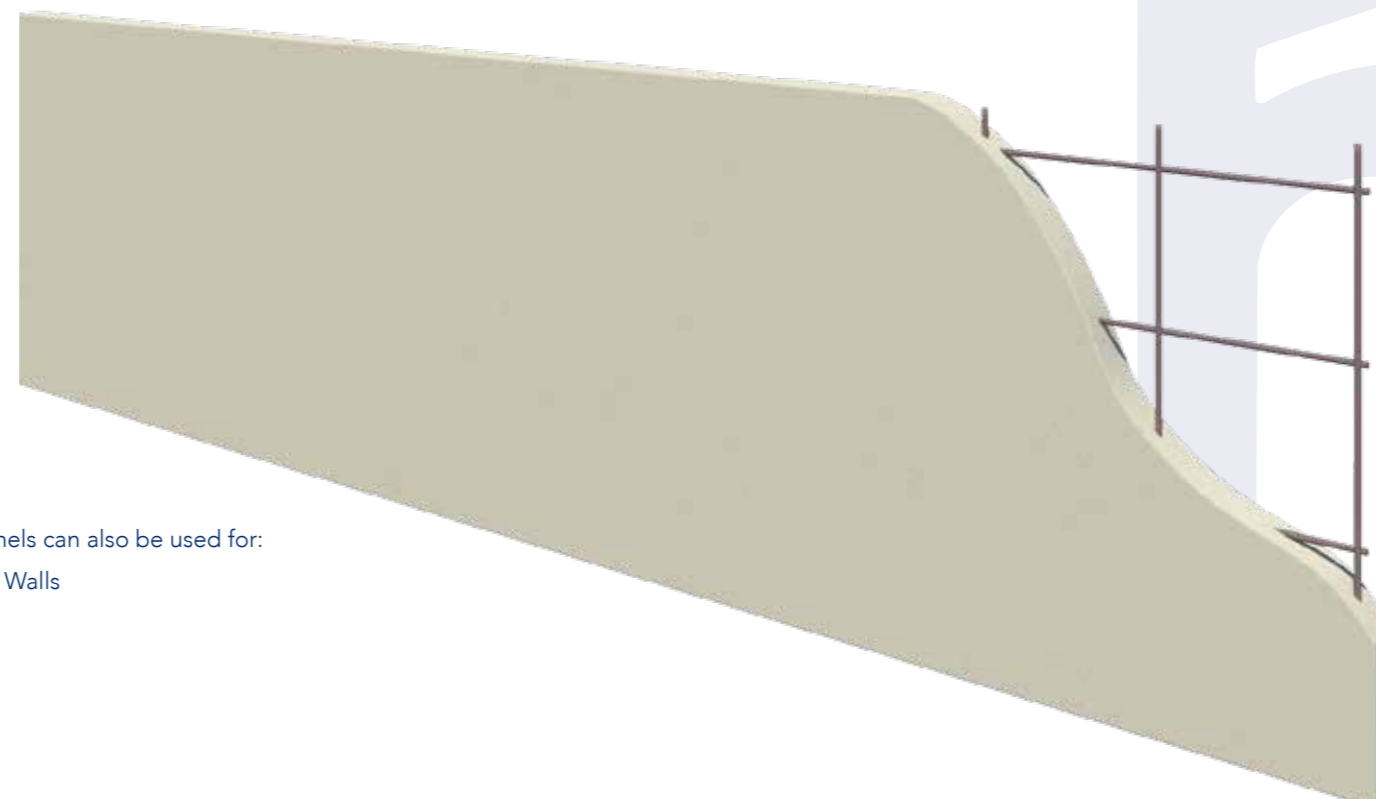

Nasahi Panels can also be used for:

- External Walls
- Flooring
- Fences

This installation guide specifies design principles for the Nasahi Party Wall System that comply with the Performance Requirements of the NCC at the time of writing. The designer must check the adequacy of the building solution for compliance with the appropriate authority.

Internal wind loads experienced by the panels, fasteners and supporting frame must be designed in accordance with the relevant Australian Standards for the site specific loads.

Stage 1: Determine the site wind load requirements including wind category, terrain category, topography and other factors that are required to calculate the wind pressures acting on the internal walls.

Stage 2: Identify whether other NCC performance requirements apply to your project. These typically include fire resistance levels and acoustic performance.

Stage 3: Select the appropriate configuration in this guide to meet the requirements outlined in Stages 1 and 2.

Stage 4: Complete the detailed design, and determine the number of panels and accessories required for the project.

FRAMING DESIGN

The load-bearing stud frame must be designed in accordance with the specific framing codes for timber or steel frames.

Timber Frames

Timber framing must be designed in accordance with the relevant parts of AS1684. Stud spacing and height should be sized to suit wind loads in accordance with local codes. Noggins must be flush fitted at a maximum of 1350mm centre spacing.

Steel Frames

Steel framing must comply with NASH Standard 2005. For steel framing the minimum framing specification is 'C' section studs and noggins of overall section size 51mm web and 32mm flange. Minimum Steel thickness must be 0.75mm in accordance with AS3623 and AS/NZ4600.

Penetrations

A service supply pipe must only be installed in the cavity of a discontinuous construction; and in the case of a pipe that serves only one sole-occupancy unit, not be fixed to the wall leaf on the side adjoining any other sole-occupancy unit and have a clearance of not less than 10mm to the other wall leaf.

Electrical outlets and taps may penetrate through plasterboard internal linings but must be offset from each other by a minimum of 300mm.

Penetrations through the fire rated Nasahi Party Wall System wall are outside the scope of this guide. A fire engineer must be consulted to approve any changes, and the use of proprietary fire rated collars are recommended.



SYSTEM OVERVIEW

Fasteners

Angle Bracket to Nasahi Panels

12G x 45mm Hex Head
SDS Type 17, Class 3 Screws



NOTE: Minimum embedment of 40mm into Nasahi Panels.

Angle Bracket into Steel Frames

12G x 20mm Hex Head Self-Drilling Class 3 Screws

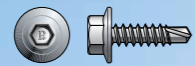

Angle Bracket to Timber Frames

12G x 25mm Hex Head Type 17 Class 3 Screws



Plasterboard Wall Lining (Min 10mm)

R2.0 Insulation

Steel I-Section

Nasahi Panel

Aluminium Angle Bracket

Optional C-Channel on Unsupported End

Wall 1 Frame

Wall 2 Frame

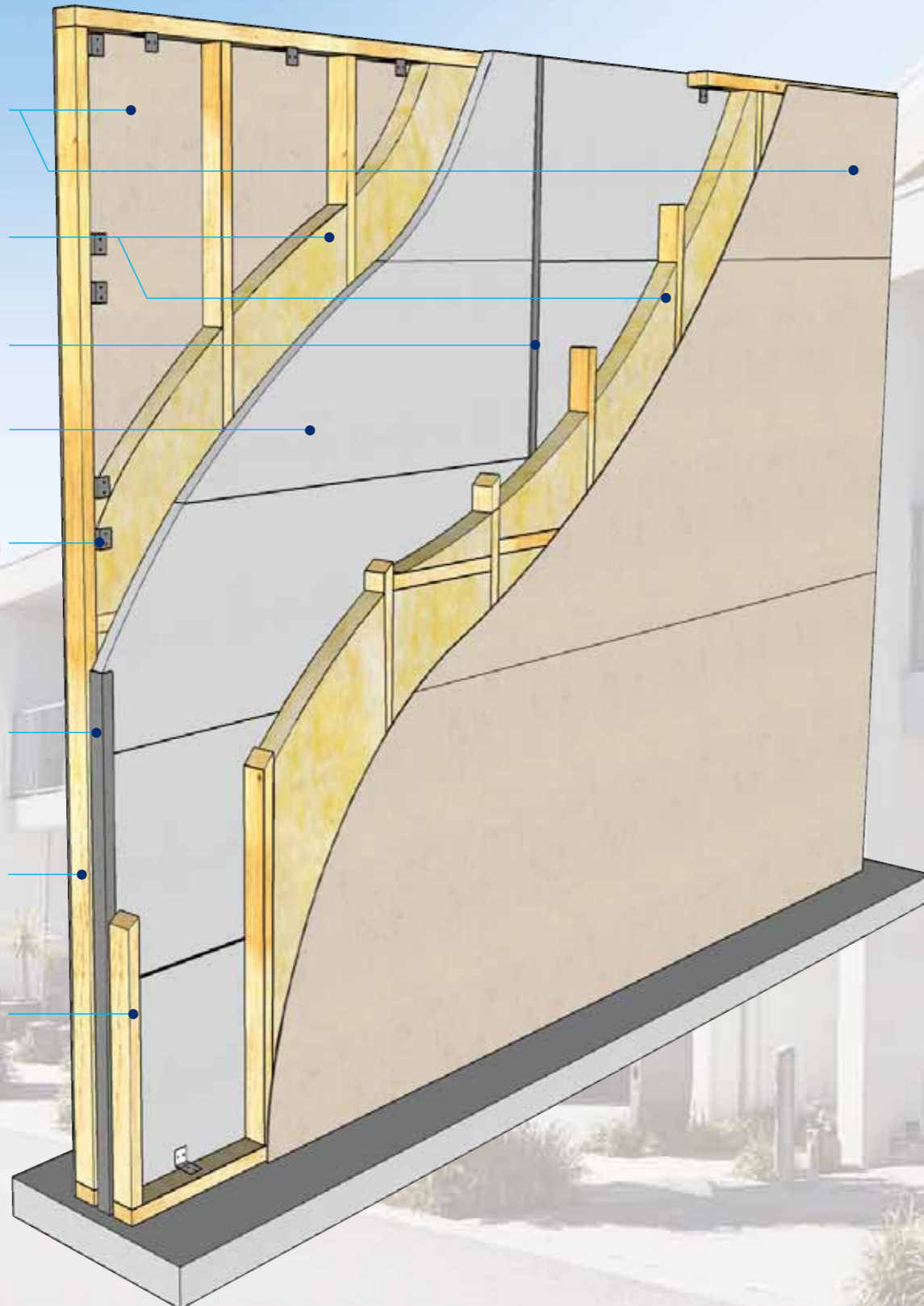

Aluminium Angle Bracket

The Nasahi aluminium angle bracket is used to attach Nasahi Panels to the periphery of the timber or steel frame.

75mm x 45mm x 50mm
BMT = 1.5 mm

Each angle bracket requires 2 Fixings in panel and 2 Fixings into Frame.



Nasahi I-Section

Galvanised steel I-section

51mm x 35mm

BMT = 0.55mm

Used to join horizontal walls longer than 2200mm.

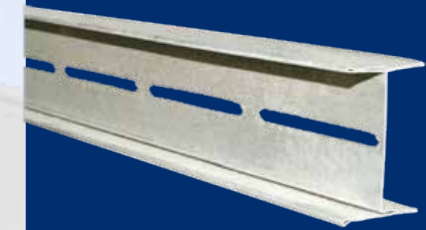

Fire Rated Plasterboard 300mm Strip

For residential applications in floor joist zone and roof space as shown in Details 2.2 on Page 25.



Nasahi C-Channel

Galvanised steel C-Channel

51mm x 35mm

BMT = 0.55mm

Used as Party Wall base as shown in Detail 3.1 on Page 26 and/or to align Nasahi Panels at wall ends.

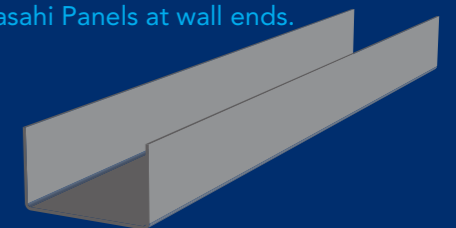

Nasahi Panels

Nasahi® Panels are manufactured from Autoclaved Aerated Concrete (AAC), embedded with coated steel reinforcing mesh, in a standard width of 600mm and up to 3300mm length.

Thickness 50mm

Dry Panel Weight (495kg/m³) 36kg

Working Panel Weight (650kg/m³) 43kg

Fire Resistant Mineral Wool

A non-combustible, moisture-resistant, non-corrosive, non-deteriorating, mildew-proof and vermin-proof mineral wool must be used to provide fire protection in party wall constructions as shown in the drawings.



Adhesive

Nasahi® Adhesive comes in 20kg bags and is used to glue, seal and patch panel joints.



Touch-up Paint

If Nasahi® Panels are cut to size, all exposed reinforcing steel must be treated with Nasahi® Corrosion Protection Touch Up Paint in accordance with the instructions on the container.



STRUCTURAL

The Nasahi Party Wall System is a non load-bearing system that is designed to act as a fire rated acoustic intertenancy wall installed onto a load-bearing timber or steel frame.

Panel Weight

Panels must be base supported and installed onto a thin bed of adhesive or into a C-track. Under no circumstances are panels to be suspended from the frame.

Internal Wind Pressure

Internal pressure is a function of the relative permeability of the external building surfaces including windows and doors, and should be calculated in accordance with AS/NZS 1170.2. The Nasahi Party Wall System has been designed to withstand typical internal pressures up to 0.5kPa. For greater pressures please contact Nasahi engineering support.

FIRE RESISTANCE

When tested to AS/NZS1530.4 the systems outlined in this guide meet the performance requirements of the NCC and provide a Fire Resistance Level (FRL) of:

-/120/90 – When installed from concrete floors to ceilings up to 3m height.

90/90/90 – Up to 10m wall height.

60/60/60 – Up to 15m wall height.

Nasahi Panels have been tested to AS/NZS1530.1 to show non-combustibility, and when exposed to fire Nasahi Panels do not emit any toxic gases or vapours.

If higher levels of fire resistance are required please contact Nasahi for project specific engineering support.

The Nasahi Party Wall System has been designed and verified by qualified acoustic engineers to provide excellent acoustic performance in low-rise multi-residential installations.

Walls in a Class 2 or 3 building separating sole occupancy units must have airborne sound insulation of $R_w + C_{tr}$ greater than 50db, or a $D_{nT,w}$ of greater than 45dB. The Nasahi Party Wall System exceeds this requirement, and by incorporating a 20mm discontinuity it complies with all relevant NCC requirements.

Table 2: Nasahi® Party Wall System Acoustic Performance

Nasahi System	**Variation**	Rw (Ctr)	System Details
P50-T70-01	70mm Timber	61 (-14)*	10mm Standard PB **Wall Frame** R2.0 Insulation 20mm cavity
P50-T90-02	90mm Timber	60 (-8)	50mm Nasahi Panel 20mm cavity
P50-S76-03	76mm Steel	65 (-15)	R2.0 Insulation **Wall Frame**
P50-S92-04	92mm Steel	66 (-13)	10mm Standard PB
P50-T90-05	13mm Standard PB	69 (-4)	**Wall Lining** 90mm Timber Frame
P50-T90-06	13mm Acoustic PB	58 (-3)	R2.0 Insulation 20mm cavity
P50-T90-07	-/120/90 Fire Rated PB	59 (-4)	50mm Nasahi Panel 20mm cavity
P50-T90-08	10mm Water Resistant PB	59 (-6)	R2.0 Insulation
P50-T90-09	6mm FC Sheet	64 (-8)	**Wall Lining**

Note: 76mm and 92mm Steel Frames have better acoustic ratings than values shown.

* $D_{nT,w}$ (Ctr) values reported for 70mm Timber Frames

INSTALLATION PROCESS

Stage 1: Preparation

1. One wall frame must be completed prior to installation of the Nasahi Party Wall System. A pre-installation check list is available on our website.

Stage 2: Base Panel Installation

2. Starting at an end, fix aluminium angle brackets:

(a) At wall studs 2 brackets per panel; and

(b) At the bottom plate at the spacings specified in Table 3 on Page 17.

3. Ensure a minimum 20mm cavity is maintained between the frame and the Nasahi Panel. Apply either a thin bed of Nasahi Panel Adhesive on the slab, or fix C-Channel track to slab using appropriate anchors as shown in Detail 3.1 on Page 26.

4. Lay the base panel horizontally with the long edge on the slab and fix the panel to the installed angle brackets.

5. Check that the Nasahi Panel is plumb and a minimum 20mm cavity is maintained between the panel and wall frame.

Stage 3: Upper Panels

6. Apply Nasahi Panel Adhesive to the base panel edge.

7. Install the next panel on top of the base panel in a stacked-bond configuration, temporarily fixing it to the frame using an Angle Bracket. Ensure panels are joined as close as possible, and are fully sealed with Nasahi Panel Adhesive.

Stage 4: Walls Longer Than 2200mm

8. Install an I-section to the unsupported panel ends as shown in Details 1.1 and 1.2 on Page 24.

9. Use a spirit level to ensure that the Nasahi Panel is plumb and minimum 20mm cavity is maintained between panel and frame. Fix the I-section to the frame by installing aluminium Angle Brackets at the top plate and bottom plate of the wall.

10. Repeat Steps 6 to 11 until the wall run is complete.

11. An optional 'C'-channel may be installed at the wall run ends for additional panel alignment.

12. Seal any gaps around the Nasahi Panel perimeter and the supporting building structure with fire-resistant mineral wool, as shown in the details provided on Pages 27 to 30.

13. In floor joist zones and roof spaces, 16mm fire rated plasterboard must be installed as shown in Details 2.1 and 2.2 on Page 25.

Stage 5: Wall Frame Completion

14. Stand the next wall frame up to the Nasahi Party Wall ensuring a minimum 20mm cavity is maintained.

15. Fix aluminium angles to the periphery of the wall frame. These serve to support the wall in the event of fire on the other side of the wall.

16. Remove temporary brackets and fixings from all locations except the periphery of the wall.

17. Services must not be fixed to or chased into Nasahi Panels. Pipes serving only one sole occupancy unit must not be fixed to the wall leaf on the side adjoining any other sole occupancy unit and must have at least 10mm clearance to the other wall leaf.

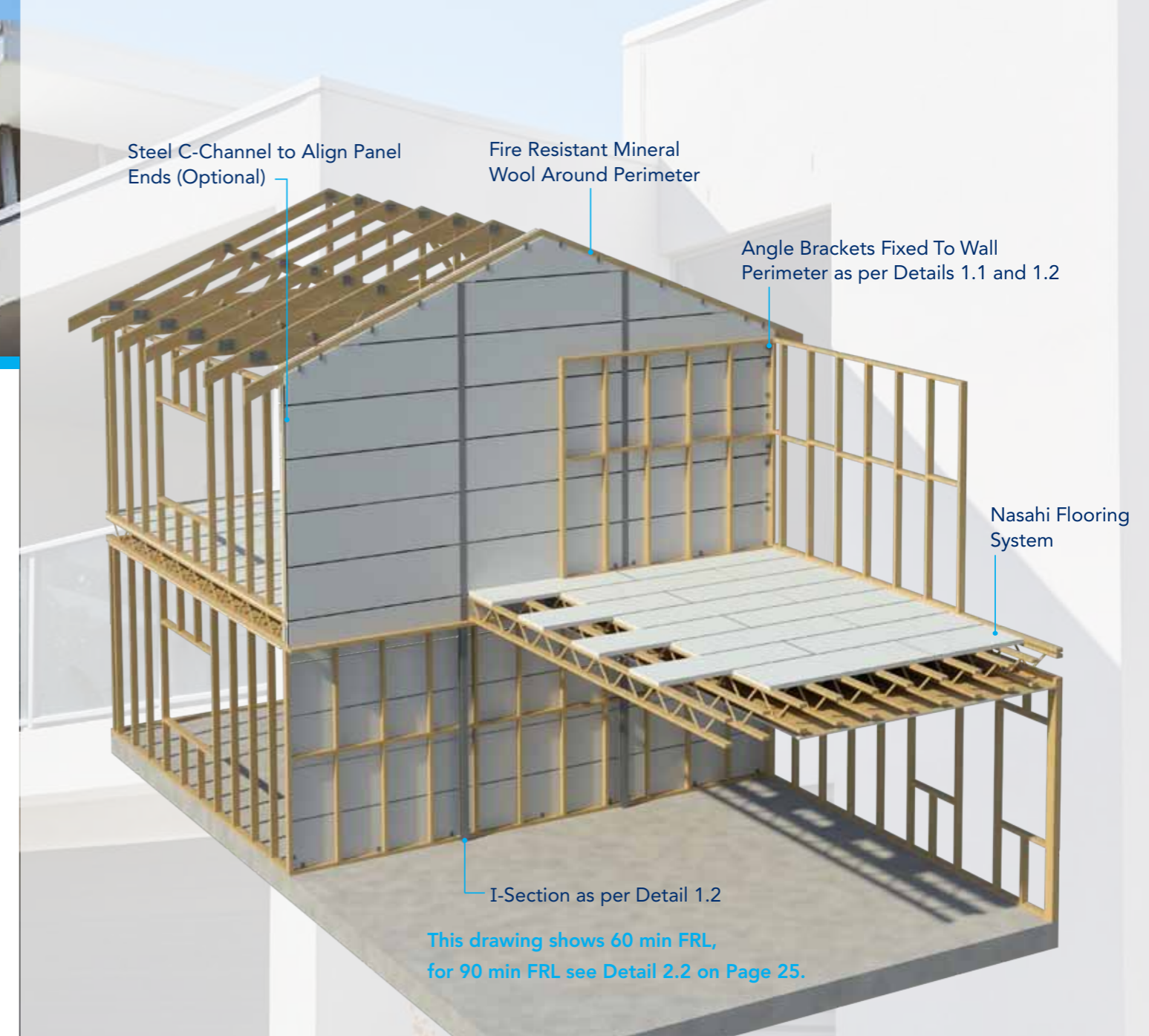

NOTE: Install min. R2.0 insulation and min. 10mm plasterboard wall linings as per manufacturers specifications. Wall lining joints must be staggered on opposite sides of the wall.

Upon project completion, the installer must complete a Nasahi Installation Compliance Certificate and submit to both Nasahi and the builder for the system to be warranted.



INSTALLATION SEQUENCE

1. Preparation

- Check that wall frame is complete.
- Cut panels to suit required wall dimensions. Coat all exposed reinforcing mesh with Nasahi Corrosion Protection Touch-Up Paint.

2. Base Panel

- Fix angle brackets to periphery of wall using two 12G x 25mm Hex Head Type 17 Screws:
 - Bottom plate at the spacings specified in Table 3 on Page 17.
 - On end studs two per panel.
 - TEMPORARY brackets are shown in RED and may be installed one stud back from end of panel, at panel centre height.
- Prepare base by either applying a bed of Nasahi Adhesive on the slab or fix C-Channel track using appropriate anchors.
- Lay panel onto slab ensuring it is level and fix to angle brackets using two 12G x 45mm Hex Head Screws.

3. Upper Panels

- Apply 2–3mm thick panel adhesive to long edge.
- Lay next panel on top and fix to angle bracket.
- For walls longer than 2200mm install I-channel.
- Fix the I-channel to the wall frame using angle brackets.
- Ensure Nasahi Panels are plumb and have minimum cavity of 20mm from frame.
- Repeat steps (a) to (e) until the wall is complete.
- Where necessary fill any gaps around Nasahi Panel and structure with Fire Resistant Mineral Wool.
- Install fire-rated plasterboard in floor joist zones and roof space as shown in Detail 2.2 on Page 25 if required for FRL 90/90/90.

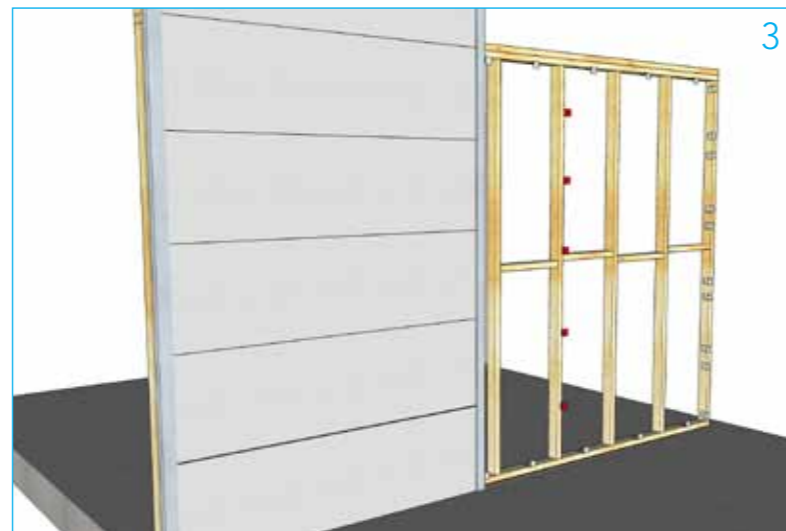
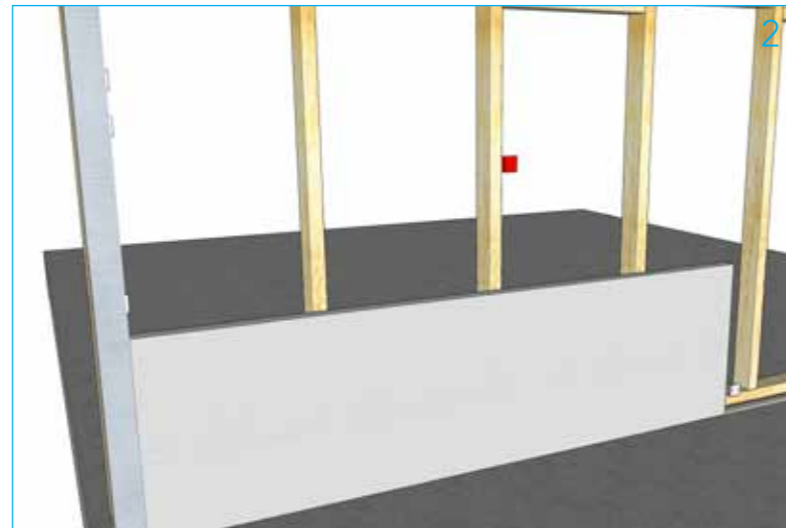
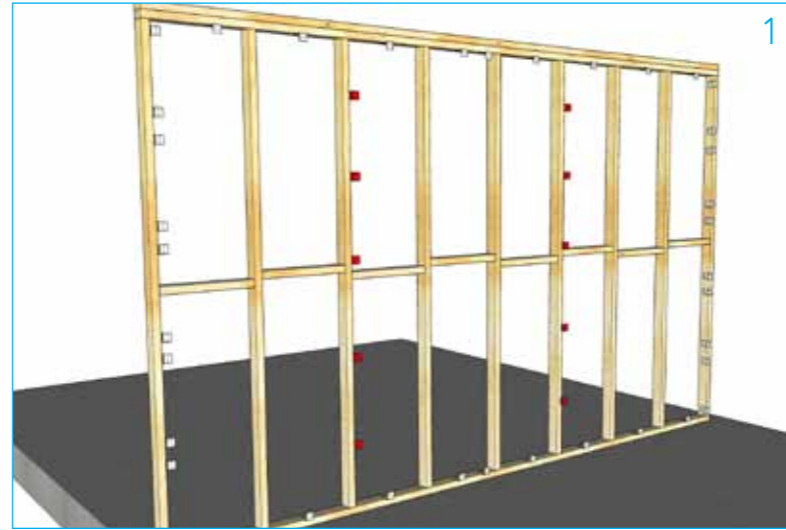

4. Complete Frame

- Stand up second frame ensuring a minimum 20mm cavity between panels is maintained.
- Fix panels to wall frame periphery using angled brackets.
- Remove temporary panel brackets.**

Finishing

- Install insulation and plasterboard as per manufacturers instructions.

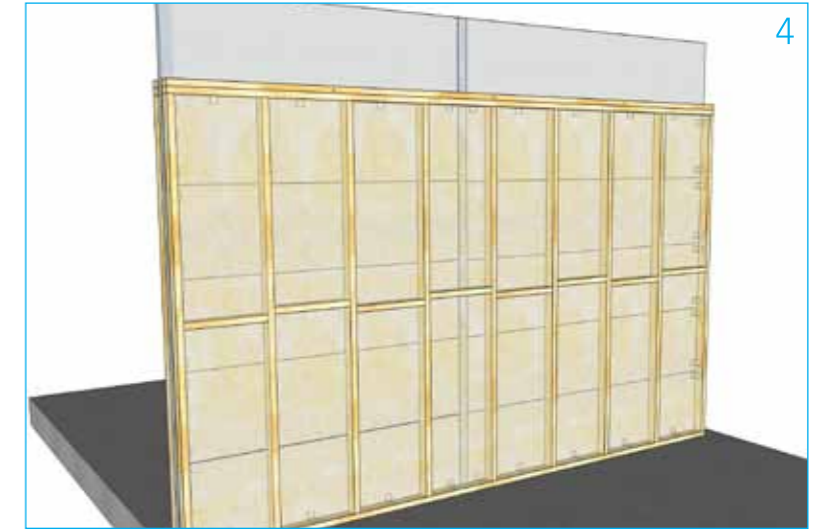

Table 3: Angle Bracket Spacing and Max Wall Height Requirement for FRL

Wall Framing	Max. Wall Height (H)	Max. Vertical Space of Aluminium Bracket	Max. Horizontal Space of Aluminium Bracket (X)	FRL
Min. 70mm deep timber or steel framing	15m	3m	1100mm	60/60/60
	6.6m	3m	400mm	90/90/90
	10m	3m	250mm	90/90/90
Min. 70mm deep timber or min. 51mm deep steel framing	3m	3m	1100mm	-/120/90

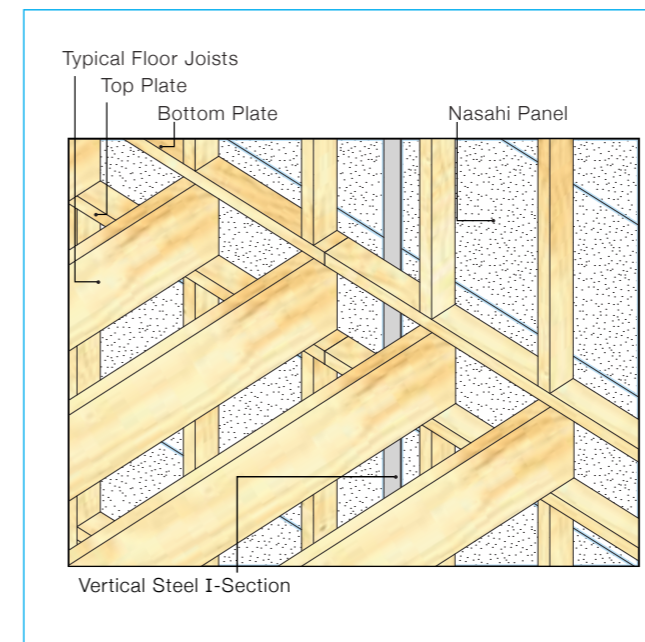

Figure 1: 60 Minute FRL Solution

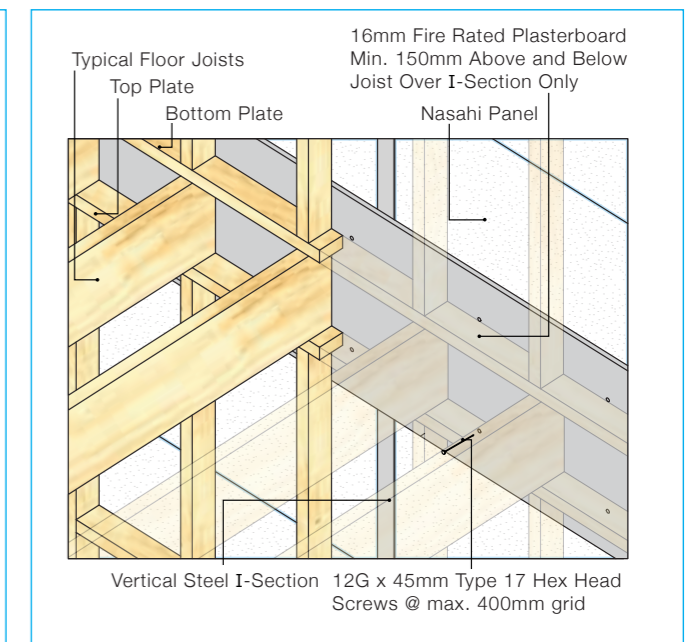

Figure 2: 90 Minute FRL Solution - Fire Rated Plasterboard Installation (Floor Joist Zone)

CUTTING PANELS

Nasahi® Panels can easily be cut to the required length, using power or hand tools.

Nasahi® Panels are delivered to site flat packed. The flat packs can be used as a cutting bench for other panels as required. Any reinforcement exposed during cutting must be coated with Nasahi® Corrosion Protection Touch Up Paint.



BASIC TOOLS REQUIRED TO INSTALL NASAHI® PANELS

- Saw with diamond blade
- Drill for screwing fasteners
- Mixing drill and buckets for panel adhesive
- Steel trowel
- Vacuum



DELIVERY

Nasahi Panels are delivered to site in flat packs of up to 20.

Each pack has a wet mass of approximately 900kg, including packaging.

Panel packs must only be stacked one pack high and must be properly supported on level ground.

If packs are to be placed on any type of structure, always consult the project engineer to verify the structural adequacy of the structure.

HANDLING

To reduce the likelihood of damage, handling of Nasahi Panels around site should be kept to a minimum. When lifting a panel, turn onto its long edge and support the weight by lifting with two people as shown below. Before lifting panels, a manual handling risk assessment must be performed to ensure personal injury risk is minimised.

Packs should be unloaded as close as possible to the installation area; however, where this is not possible Nasahi recommends the use of trolleys and/or other mechanical devices.





All quarry products, including bricks, concrete and Nasahi® Panels contain Crystalline Silica, or Silica Dust.

SAFETY

Prolonged exposure to Silica Dust without the correct PPE can be harmful and potentially cause skin irritation and life-threatening health hazards such as bronchitis, silicosis and lung cancer.

Silica dust is generated when cutting, drilling or moving the panels.

The site should be cleaned of dust regularly and when using power tools these should be fitted with an efficient, well-maintained dust extraction system.

Nasahi® Panels do not contain any additives that are known to cause health problems; however, because of the risk of exposure to Silica Dust it is recommended that the correct PPE is worn.

The Nasahi® Party Wall System Installer is responsible for informing all employees of these Health and Safety requirements under the Occupational Health and Safety Act.



Personal Protective Equipment (PPE)

When working with Nasahi® Panels, it is recommended that the following Australian compliant PPE is worn as a minimum:

- P1 or P2 Dust masks
- Protective Glasses / Goggles
- Ear Plugs / Ear Muffs – Class 5
- Gloves, long sleeve shirt and long pants
- Protective footwear.

Hazardous Materials

For MSDS of all components sold by Nasahi®, please visit our website.

NCC Volume One – Covers commercial, residential and public buildings defined as Class 2 to 9. Typical examples include multi-family dwellings, commercial, health buildings and anything not covered under Volume Two.

NCC Volume Two – Covers domestic constructions defined as Class 1 and 10. Typical examples include single-family dwellings, houses and garages.

It is the responsibility of the builder to ensure the system is designed in accordance with this installation manual and that all site-specific performance provisions outlined in the relevant sections of the NCC are met.

The Nasahi Party Wall System has been certified to meet the following provisions of the National Construction Code for Volume One and Volume Two as listed below:

	Volume One	Volume Two
Structural	BP1.1 & BP1.2	P2.1.1
Fire	CP1 & CP2	P2.3.1
Acoustic	FP5.2 & FP5.5	P2.4.6

The Nasahi® CodeMark Certificate can be downloaded from our website.

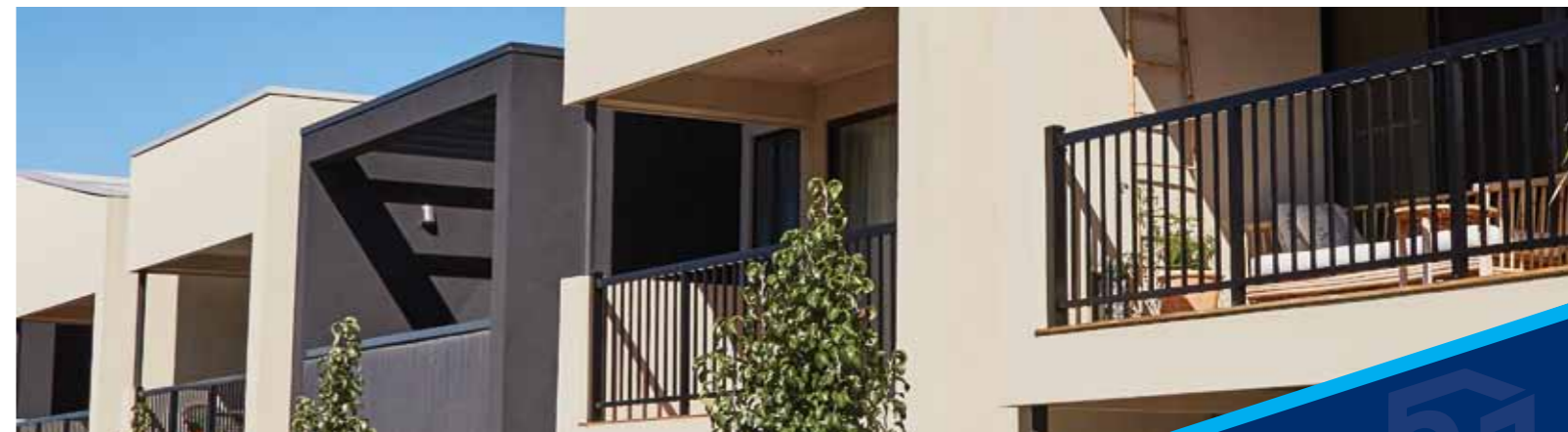



MATERIAL PROPERTIES

Property	Standard	Value	Units
Ambient Density, amb	AS/NZS 4456.8	650	kg/m ³
Dry ¹ Density, dry	AS 5146.2	495	kg/m ³
Mean Compressive Strength	AS 5146.2	4.3	MPa
Characteristic Unconfined Compressive Strength, f'uc	AS 5146.2	2.8	MPa
Mean Flexural Strength	AS 5146.2	1.07	MPa
Characteristic Flexural Strength, f'ut	AS 5146.2	0.50	MPa
Mean Cold Water Absorption	AS/NZS 4456.14	69.0	%
Design Serviceability Limit State Deflection Limit, max	AS 1170	SPAN/240	

Notes: 1. Dry density is achieved by oven drying specimens so that the moisture content is close to 0%.

PANEL REINFORCING LAYOUT

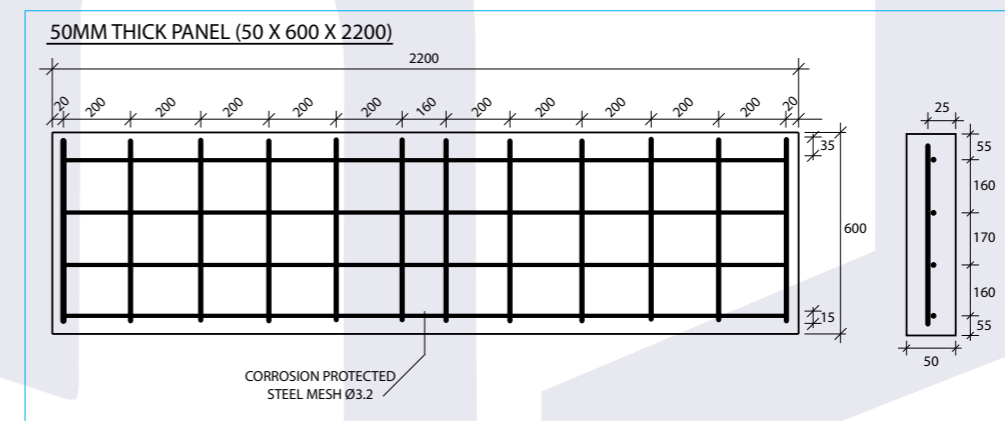

DETAILED DRAWINGS

NOTE: Angle Fixings MUST BE ONE (1) at the TOP plate and ONE (1) at Bottom Plate at spacings as per table below.

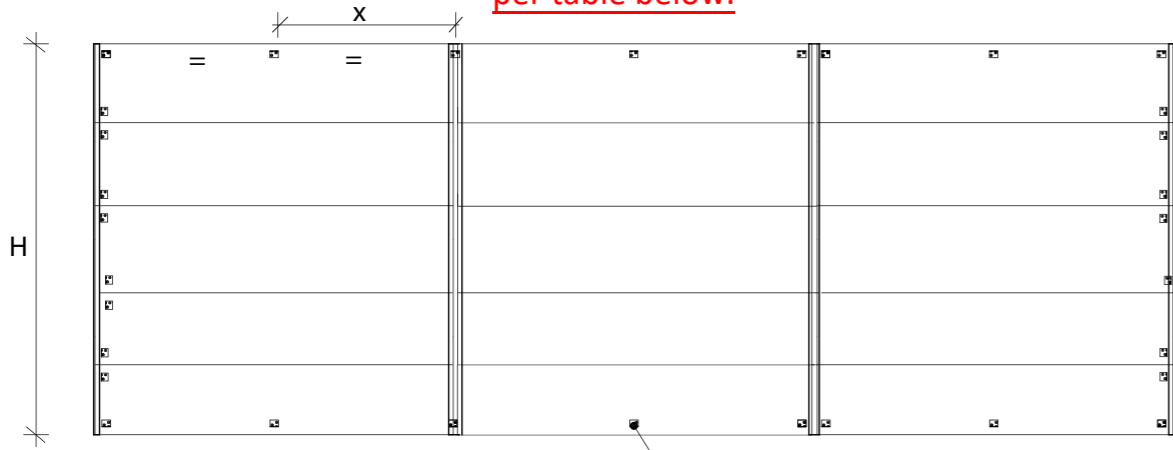

DETAIL 1.1: PARTY WALL LAYOUT

Each angle bracket requires 2 Fixings into Panels and 2 Fixings into Frame

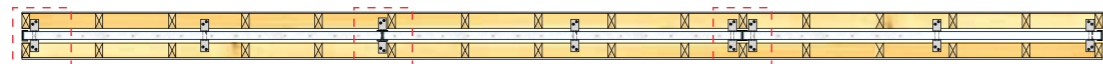

End Detail (Optional C-Channel)

Panel Joint Option 1 (Fix through I-Section)

Panel Joint Option 2 (Fix Both Sides of I-Section)

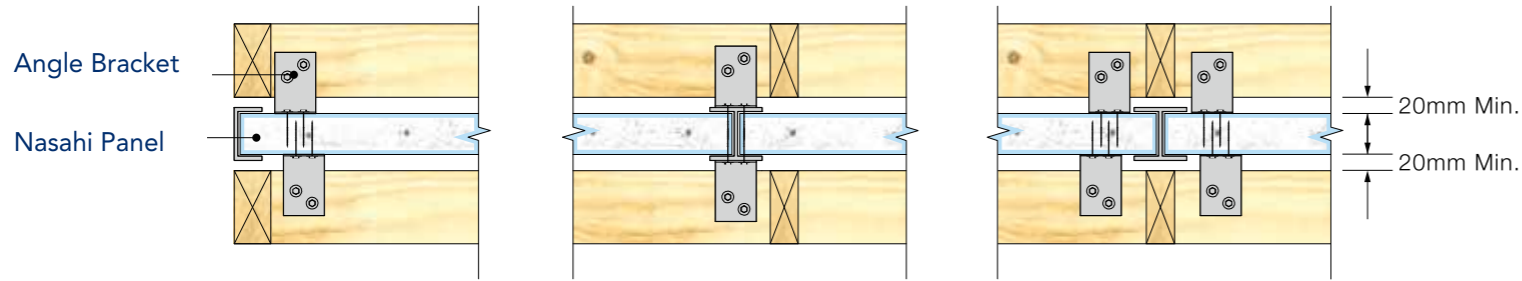

See page 34 for Optional C-Channel fixing

• Angle brackets must be spaced in accordance with wind loads and FRL requirements as specified in this installation guide.

DETAIL 1.2: ANGLE BRACKET POSITIONING

Table A: Angle Bracket Spacing and Max. Wall Height Requirement for FRL

Wall Framing	Max. Wall Height (H)	Max. Vertical Space of Aluminium Bracket	Max. Horizontal Space of Aluminium Bracket (X)	FRL
Min. 70mm deep timber or steel framing	15m	3m	1100mm	60/60/60
	6.6m	3m	400mm	90/90/90
	10m	3m	250mm	90/90/90
Min. 70mm deep timber or min. 51mm deep steel framing	3m	3m	1100mm	-/120/90

When restraining panels with a 'C' channel or 'H' section a minimum dimension of 75mm must be used. To achieve this, the panel below may need to be cut accordingly.

Note: 'Y' - All panels not restrained by a 'H' section and are less than 1100mm must be restrained by having two (2) brackets per panel piece.

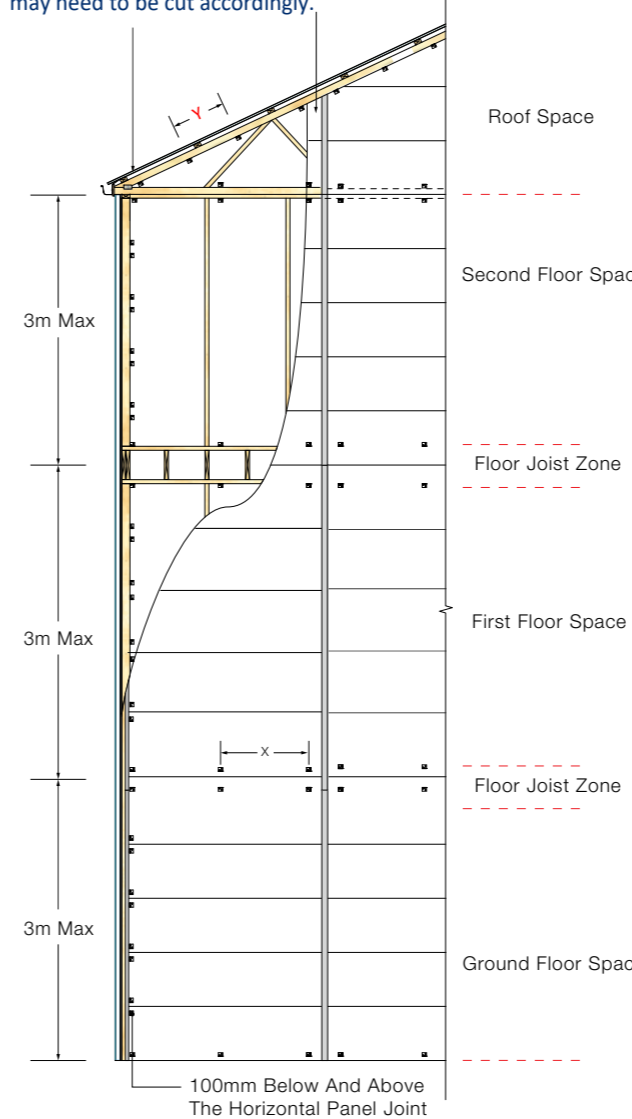

DETAIL 2.1: MULTI-STOREY INSTALLATION (60 MINUTE FRL)

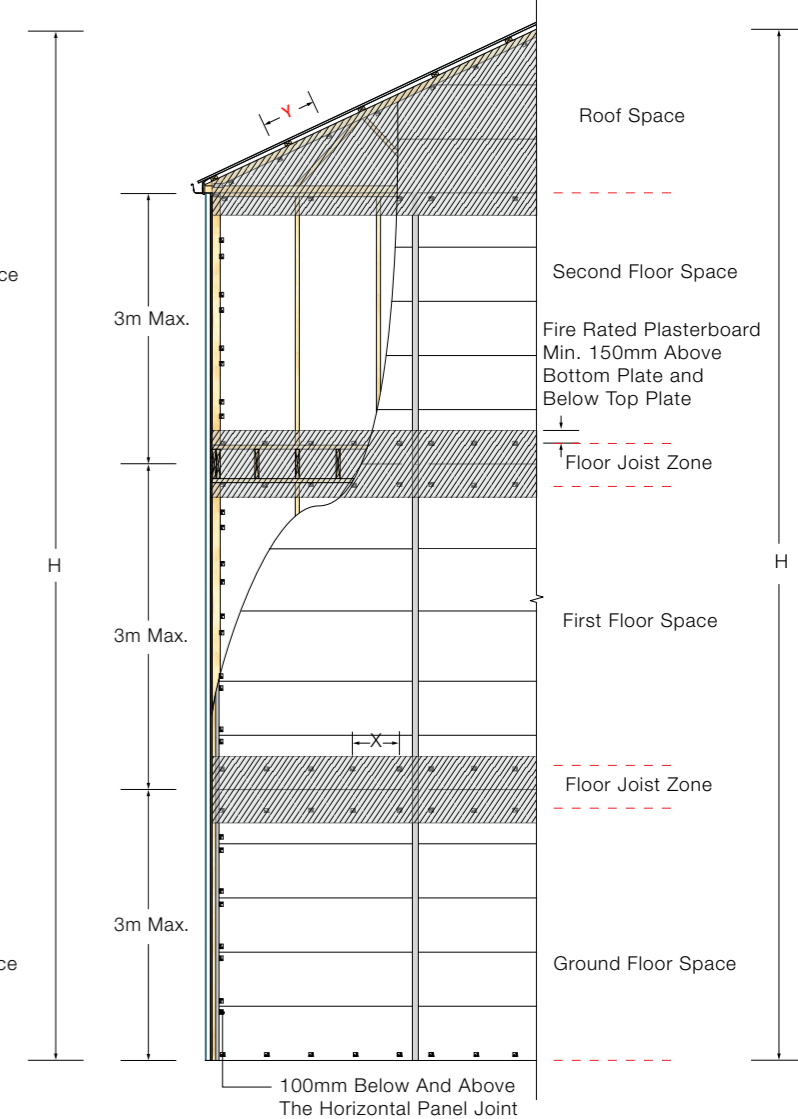

DETAIL 2.2: MULTI-STOREY FIRE BOARD INSTALLATION (90 MINUTE FRL)

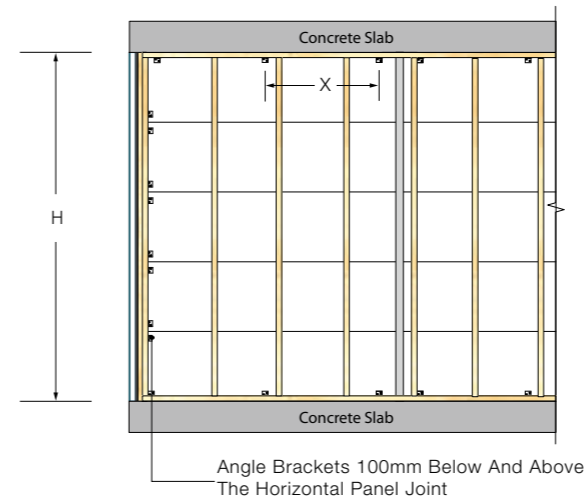

DETAIL 2.3: CONCRETE FLOOR TO CONCRETE SOFFIT (120 MINUTE FRL)

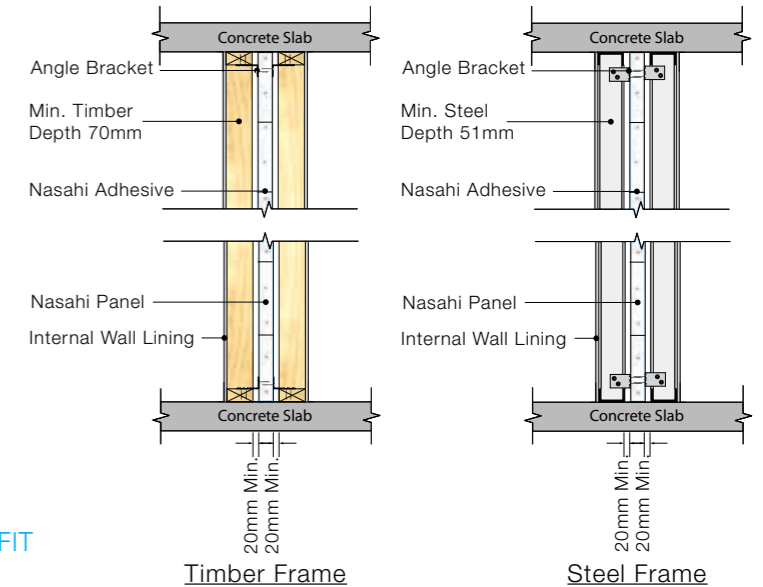

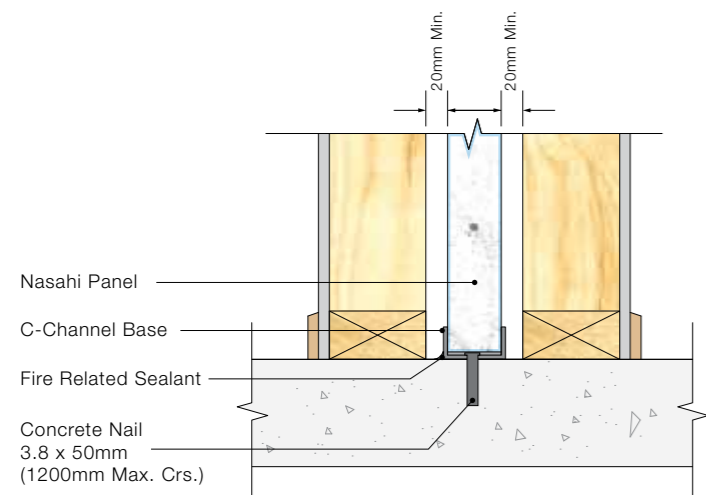

DETAIL 3.1: PARTY WALL BASE - OPTION 1 (C-CHANNEL)

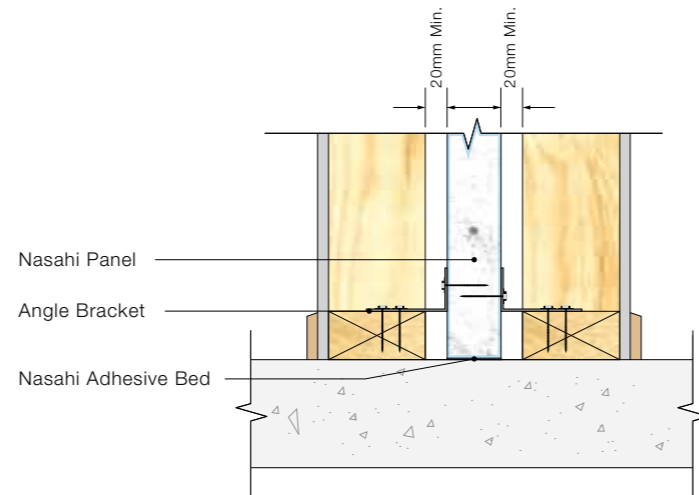

DETAIL 3.1: PARTY WALL BASE - OPTION 2 (NASAHİ ADHESIVE BAG)

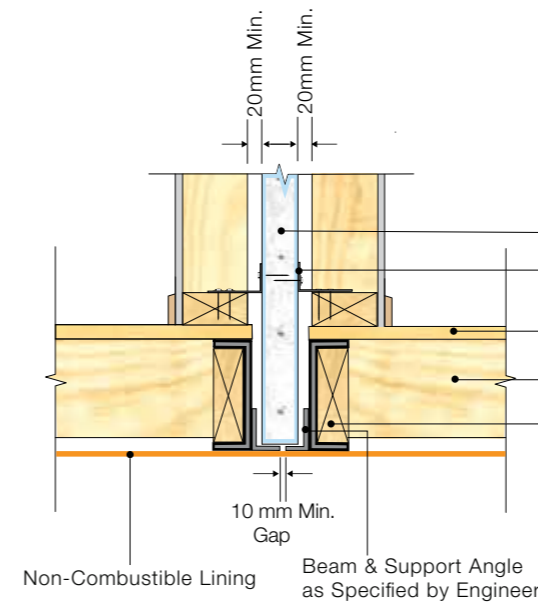

DETAIL 3.4A: CANTILEVER BEAM PANEL SUPPORT (60Min)

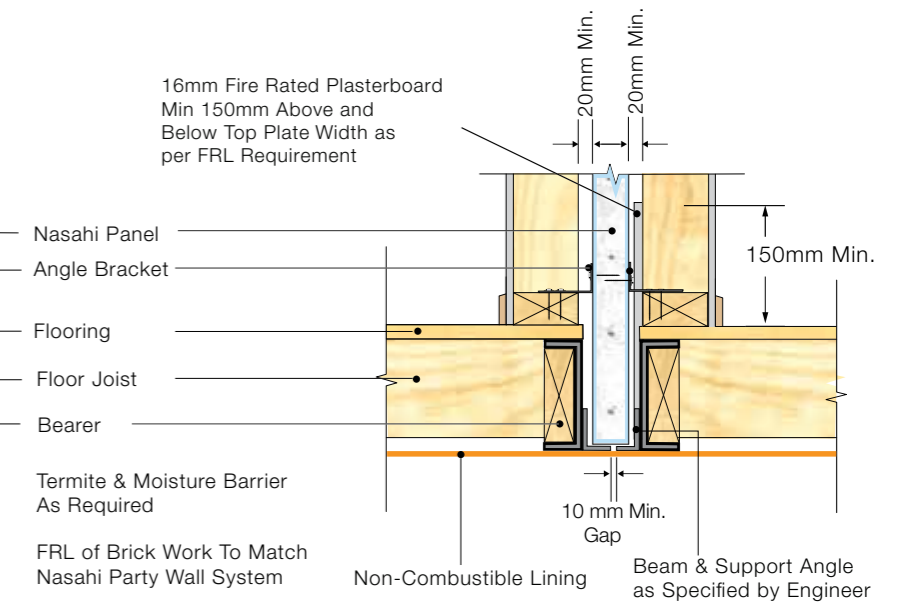

DETAIL 3.4B: CANTILEVER BEAM PANEL SUPPORT (90Min)

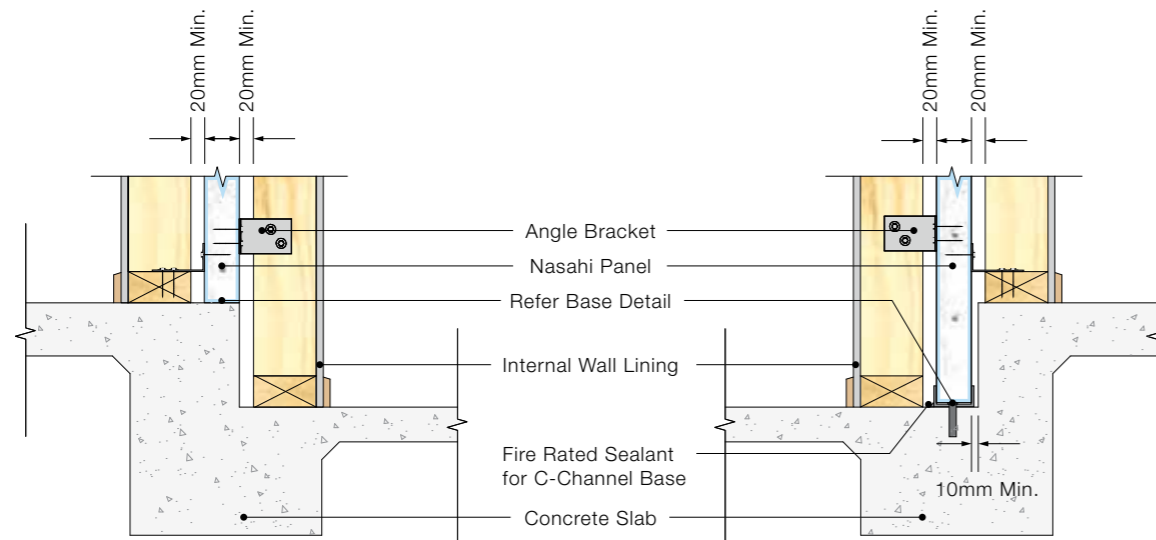

DETAIL 3.3: STEP IN SLAB (OPTION 1)

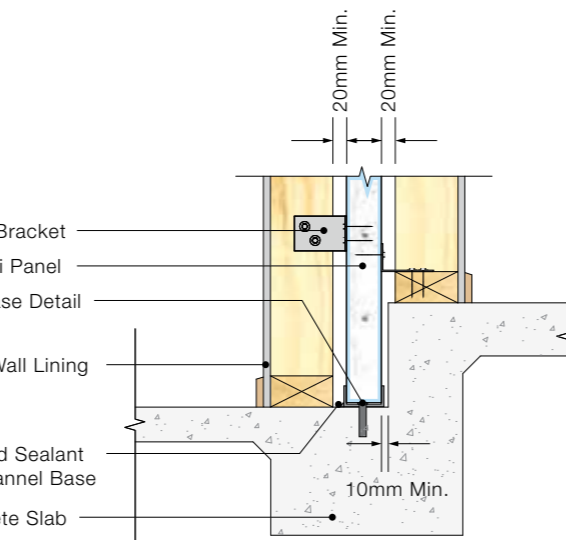

DETAIL 3.3: STEP IN SLAB (OPTION 2)

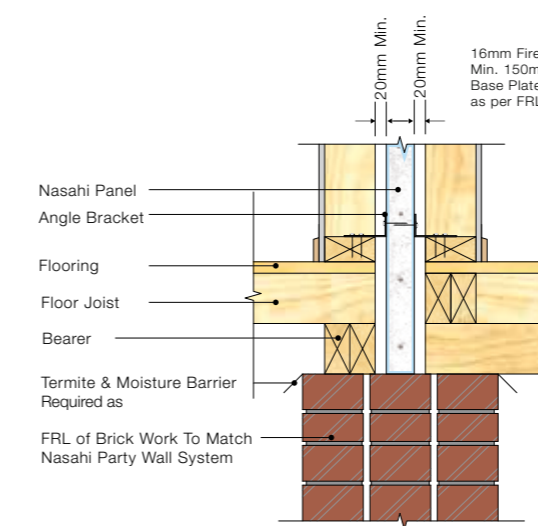

DETAIL 3.2A: MASONRY/STRIP FOOTING BASE (60Min FRL)

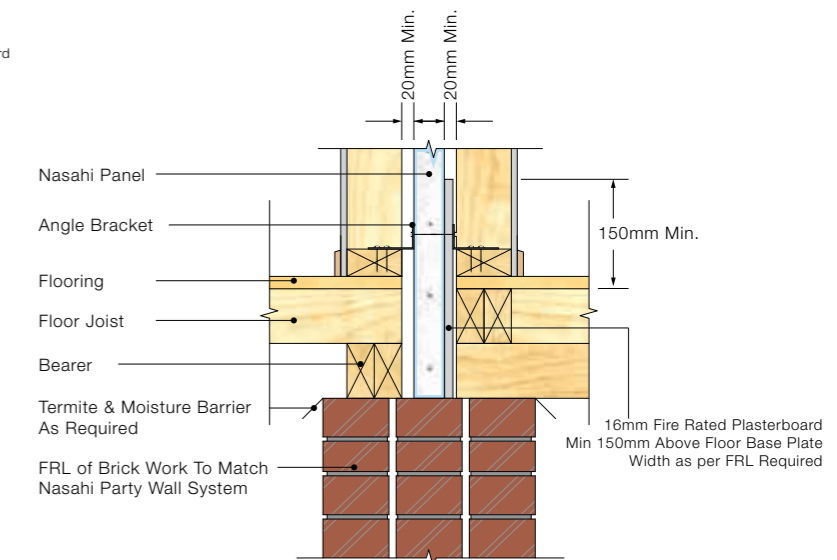

DETAIL 3.2B: MASONRY/STRIP FOOTING BASE (90Min FRL)

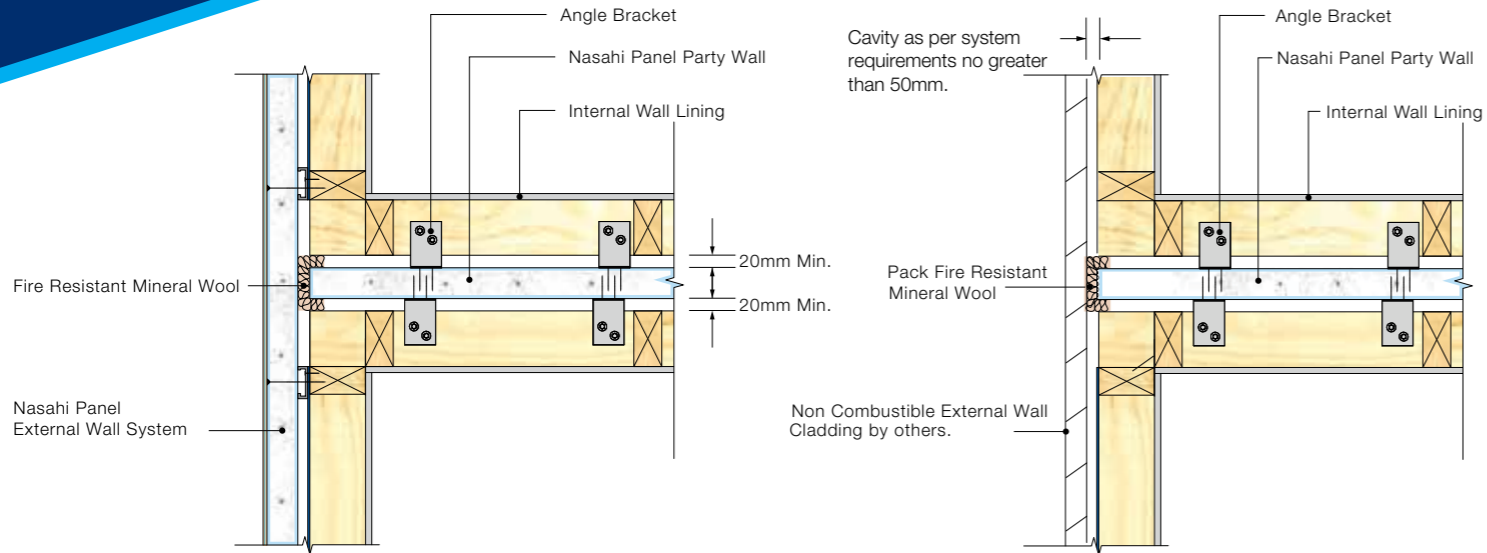

DETAIL 4.1: PARTY WALL TO EXTERNAL WALL JUNCTION

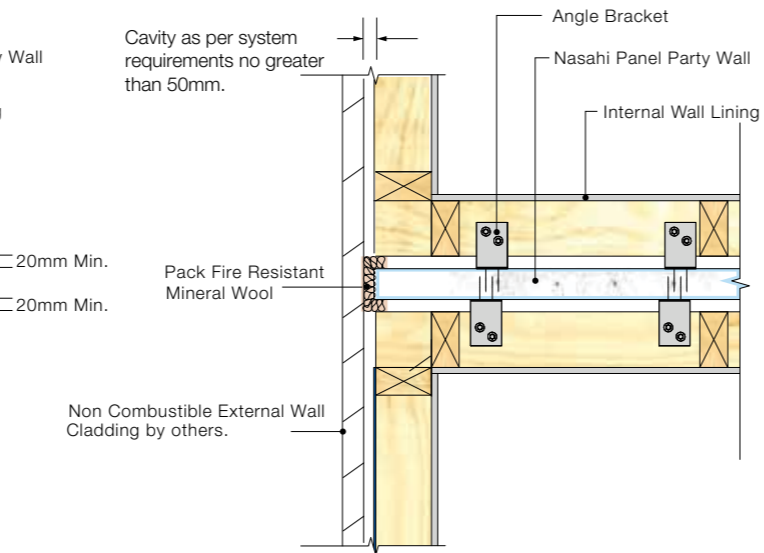

DETAIL 4.1A: PARTY WALL TO OTHER EXTERNAL WALL JUNCTION CLADDING

The NCC (Volume 2, Class 1 and 10a buildings) relating to separating walls, clause 3.7.1.8(e) notes;

(e) Where a building has a masonry veneer external wall, any gaps between the separating walls and the external non-combustible veneer wall must be:

- (i) Not more than 50mm; and
- (ii) packed with a mineral fibre or other suitable fire-resistant material with the packing arrangement to maintain any weather proofing requirement of part 3.3.4

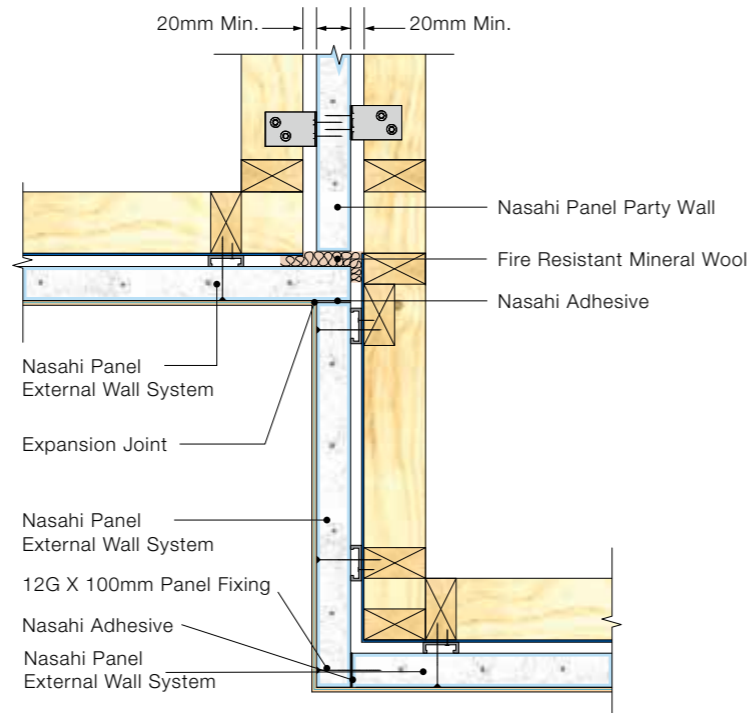

DETAIL 4.2: PARTY WALL TO EXTERNAL WALL JUNCTION

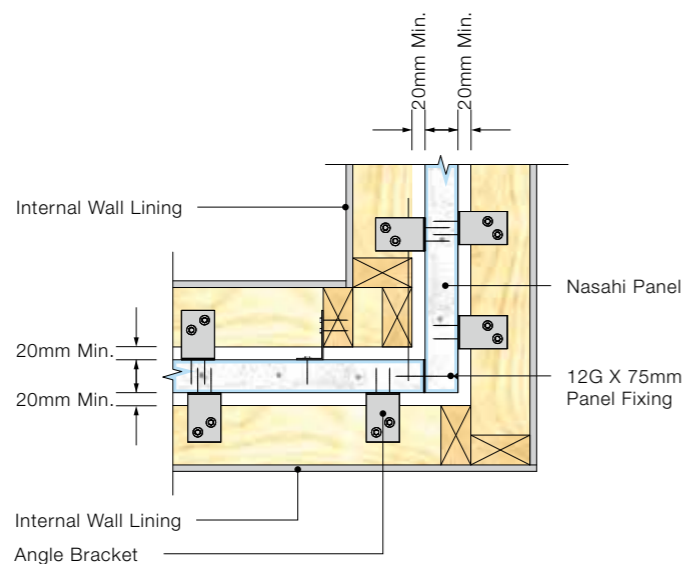

DETAIL 4.3: TYPICAL PARTY WALL CORNER

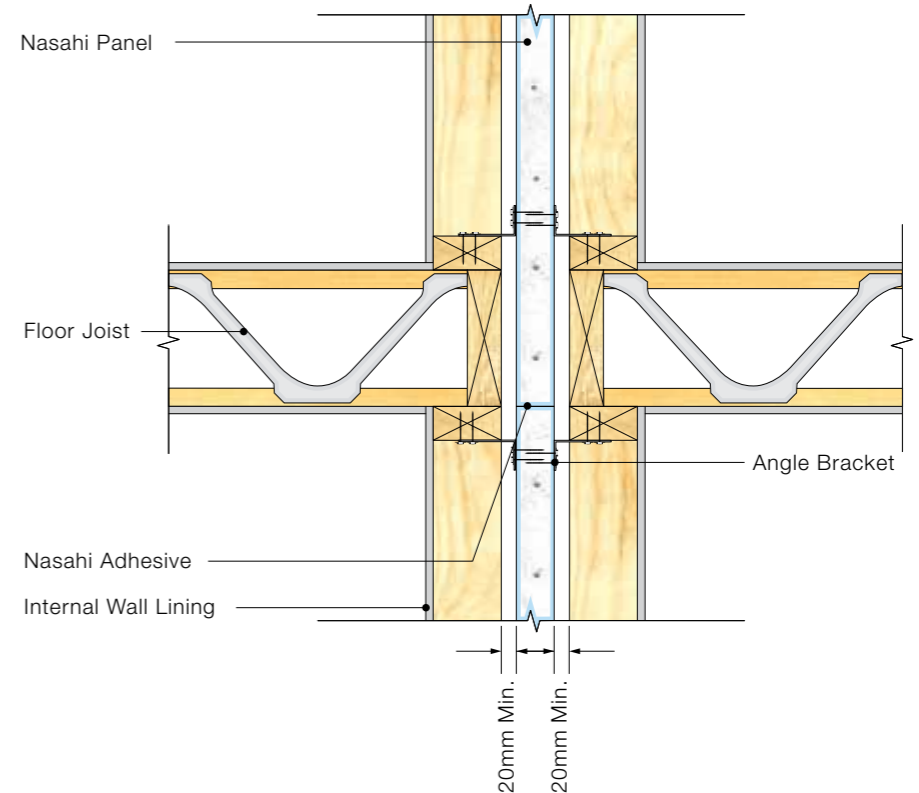

5.1A PARTY WALL TYPICAL WALL - 60 MIN FLOOR JUNCTION DETAIL - ELEVATION VIEW

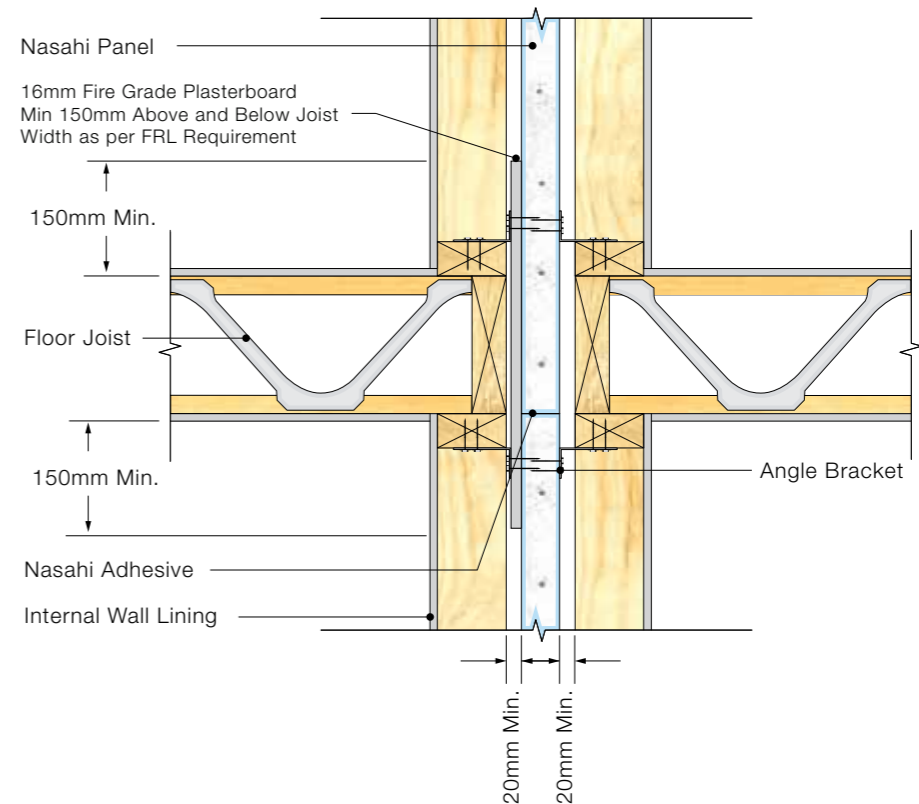

5.1B PARTY WALL TYPICAL WALL - 90 MIN FLOOR JUNCTION DETAIL - ELEVATION VIEW

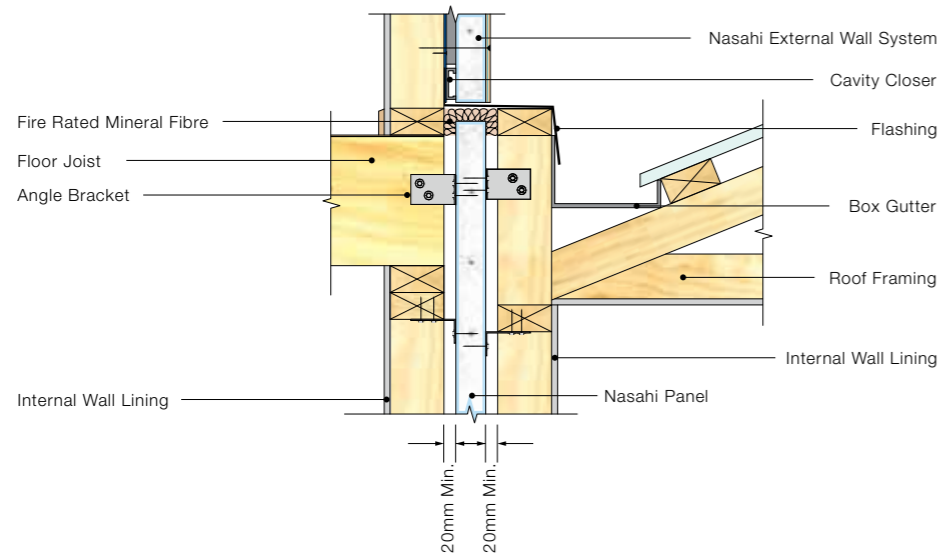

5.2A PARTY WALL (60MIN) TO EXTERNAL WALL TRANSITION

Note: For 60 minute Fire Resistance Level (FRL), plasterboard installation in floor joist areas is not required.

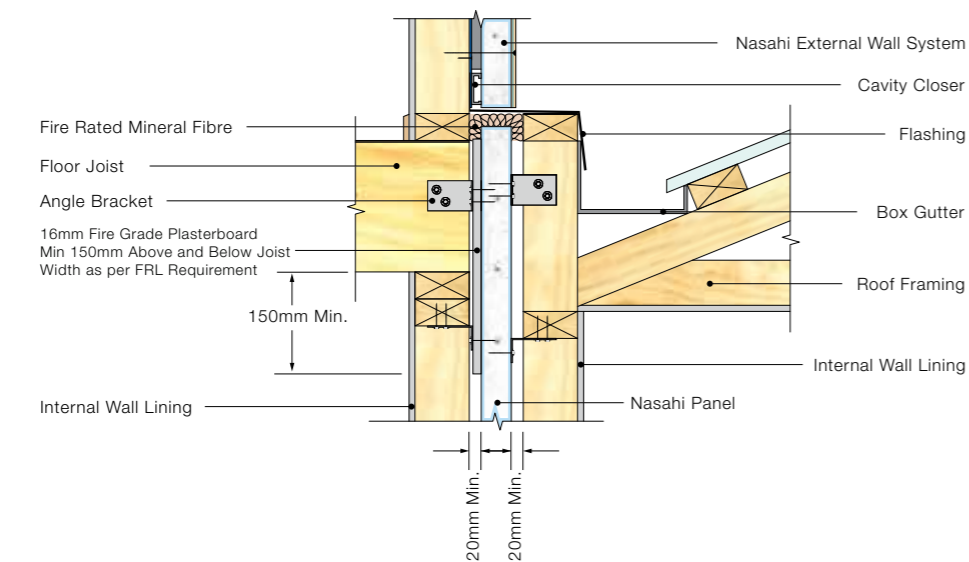

5.2B PARTY WALL (90MIN) TO EXTERNAL WALL TRANSITION

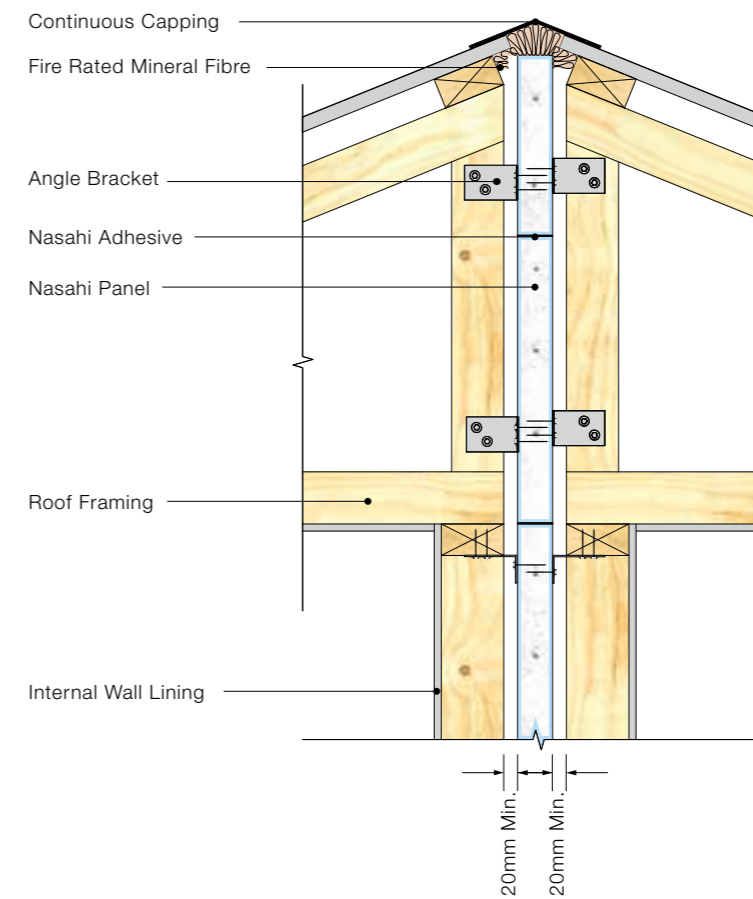

6.1A PARTY WALL - 60 MIN PITCHED ROOF JUNCTION DET

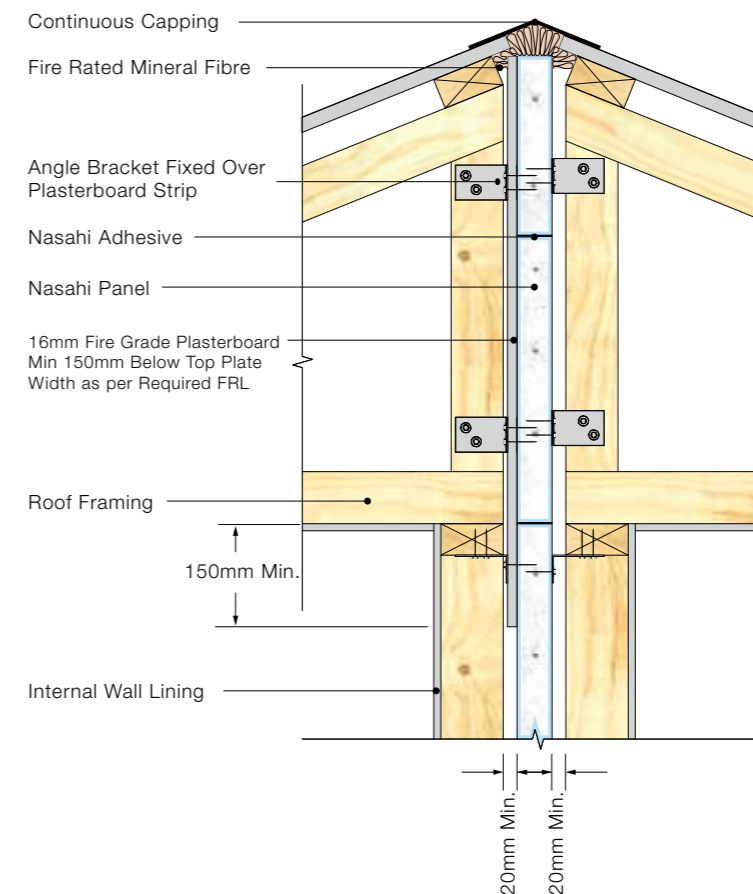

6.1B PARTY WALL - 90 MIN PITCHED ROOF JUNCTION DETAIL

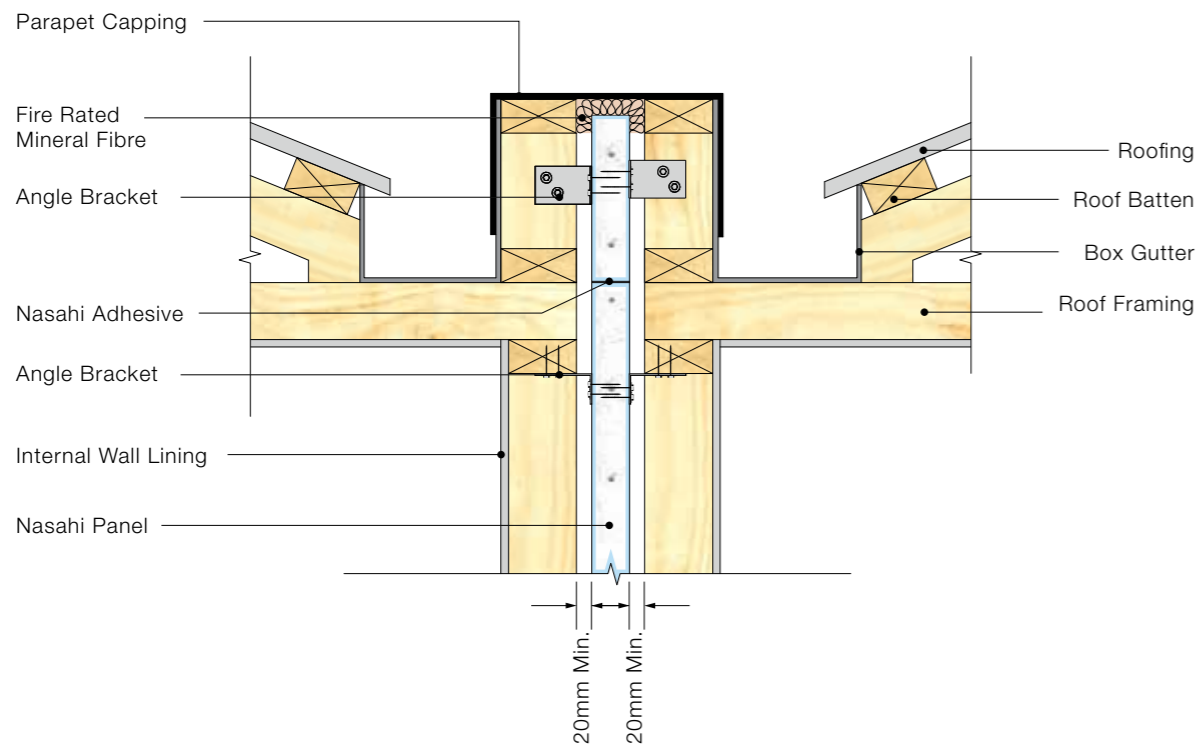

6.2A PARTY WALL - 60 MIN ROOF PARAPET JUNCTION DETAIL

Note: For 60 minute Fire Resistance Level (FRL), plasterboard installation in top plate joint areas is not required.

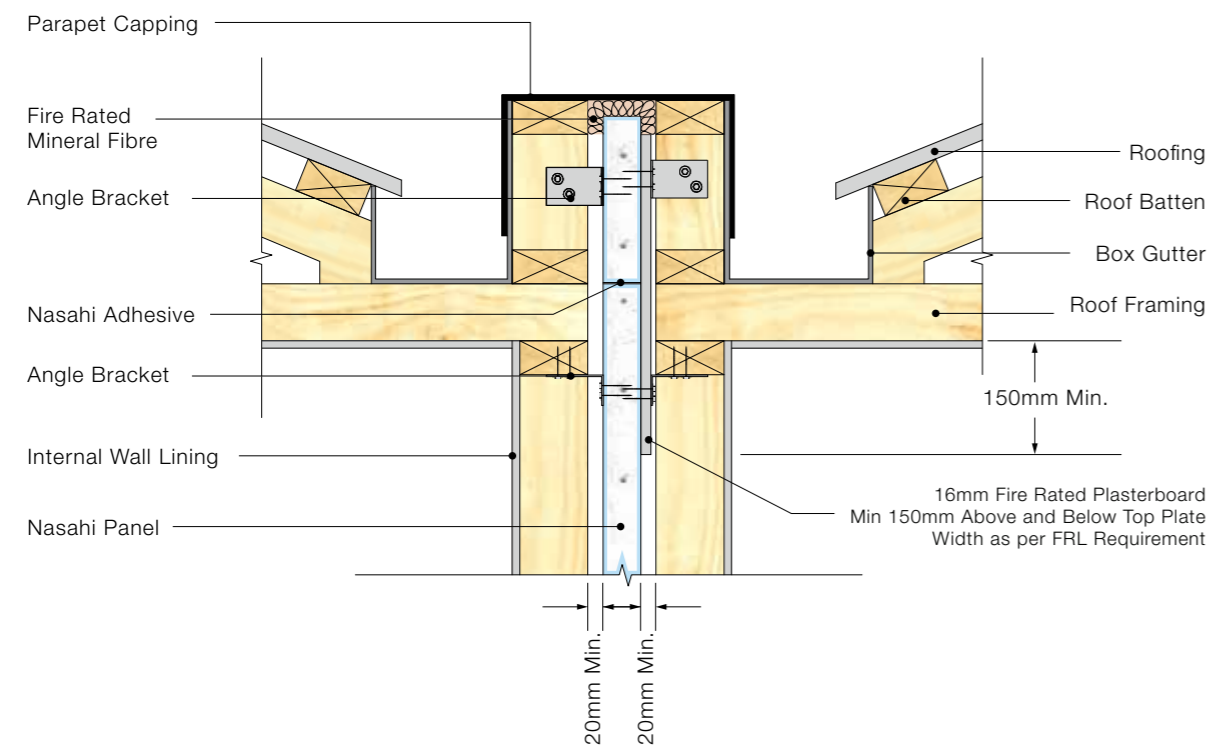

6.2B PARTY WALL - 90 MIN ROOF PARAPET JUNCTION DETAIL

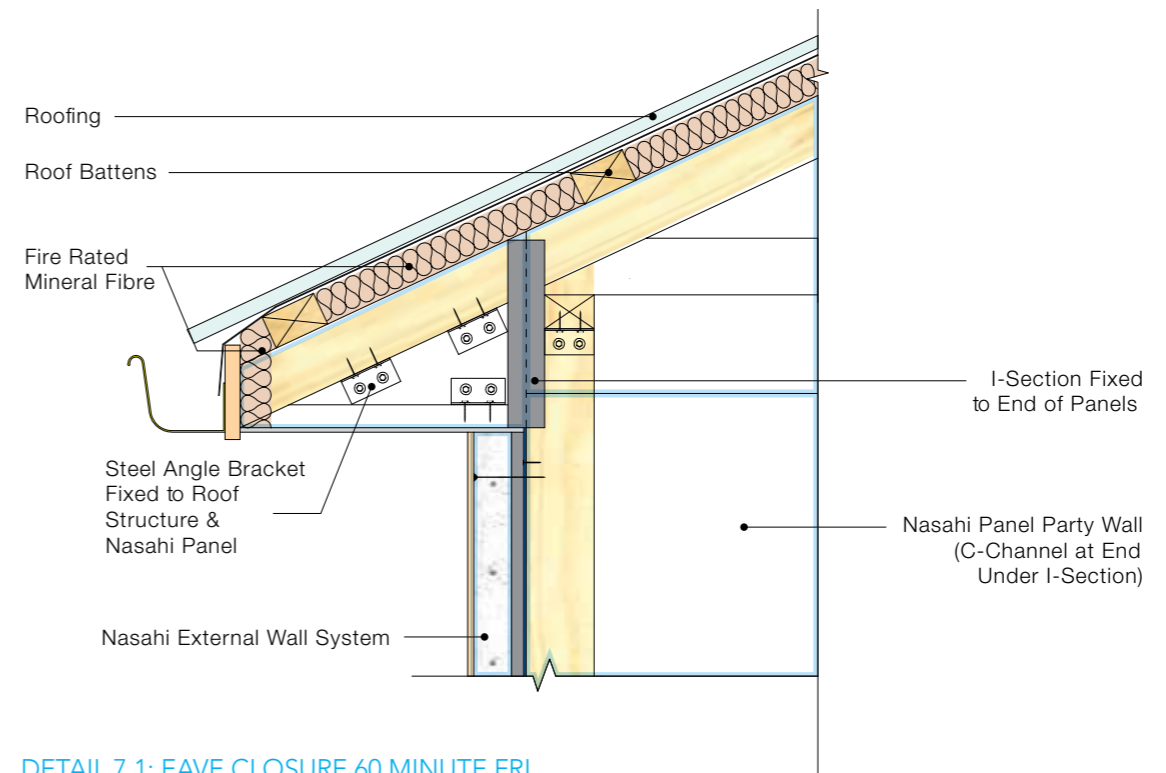

DETAIL 7.1: EAVE CLOSURE 60 MINUTE FRL

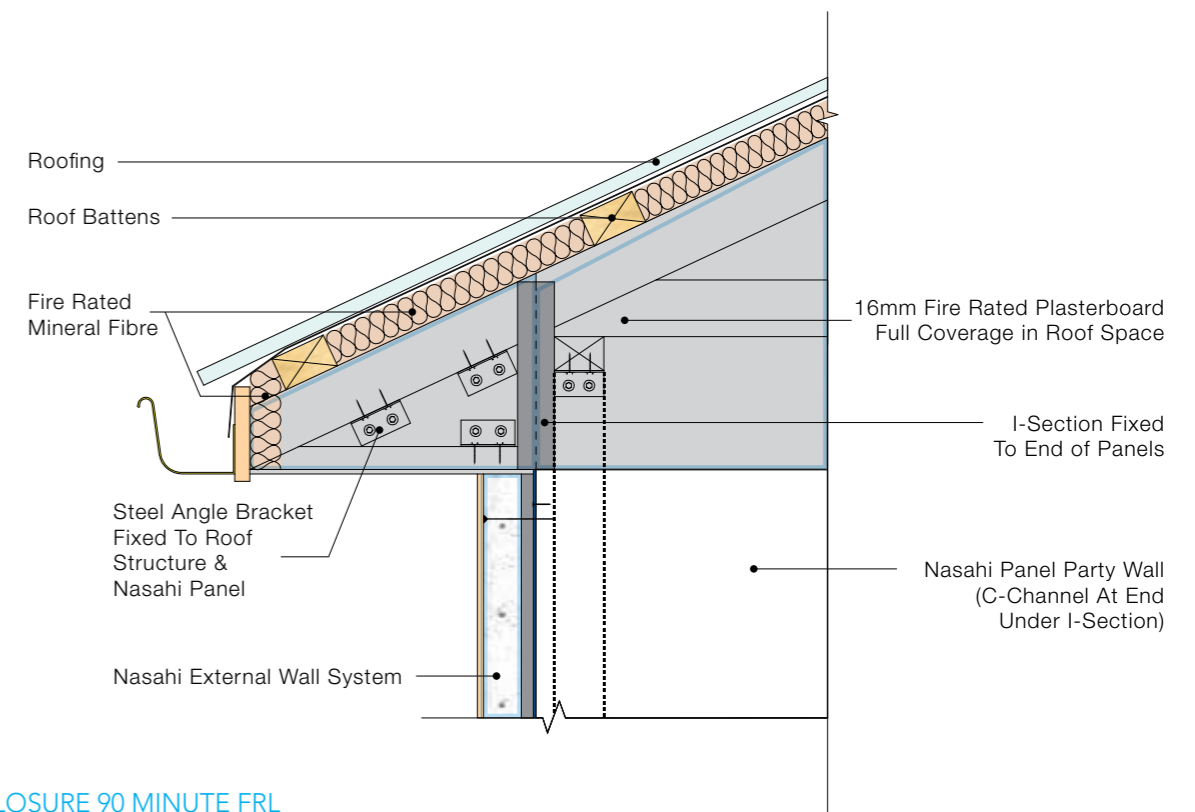

DETAIL 7.2: EAVE CLOSURE 90 MINUTE FRL

Note: Panels require end restraint of 150mm minimum. This may be an issue when roof space is limited. To meet the requirement the panel below may need to be cut. Additional details and special cases can be found in the Technical Notes Section on our website.

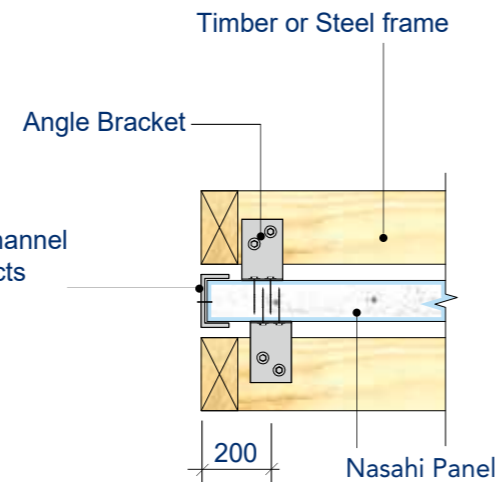
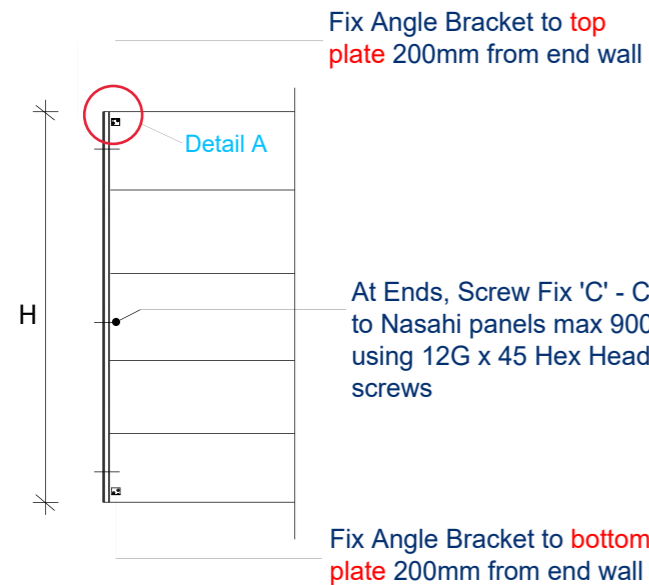

Expanded View Detail A

End Detail (Optional C-Channel) from page 24

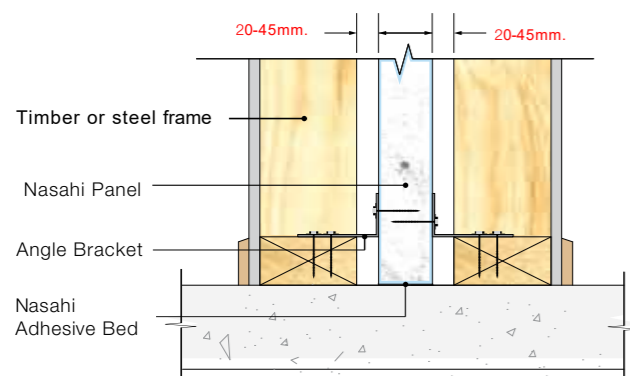

Cavity distance between panels & frame

5.0mm ϕ holes staggered 15mm (min) from ends.

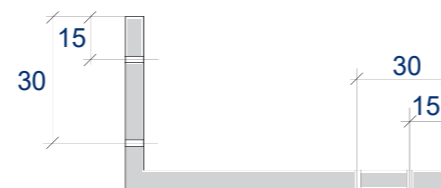

Aluminium angle. 50mm wide x (45mm x 75mm long) x 1.5BMT

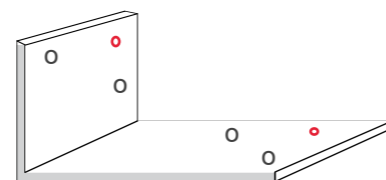

NOTES:

If required, it is permitted to site drill another 5mm diam hole (hole shown in red) so as to achieve a maximum 45mm gap between the frame and panel. The hole to be no less than 15mm from the edge of the angle in line with the existing hole closest to the edge.

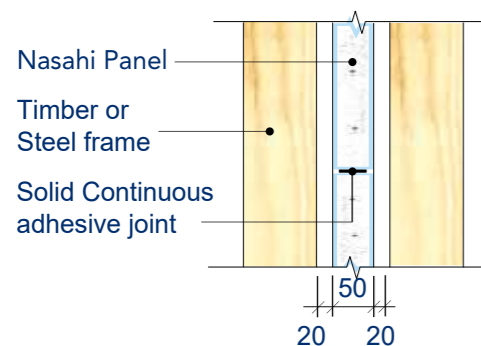

Panel Joint Detail

Note: It is not a requirement to flush joint adhesive to panel face. A continuous adhesive joint with a minimum 30mm must be provided for fire & acoustic requirements.

Guarantee

Nasahi guarantee the systems described in its literature for 7 years, subject to the terms and conditions of the Nasahi Warranty document on our website. Nasahi does not guarantee components, products or services, such as installation supplied by others. Nasahi recommends that only products, components and systems recommended by it be used. Nasahi Approved Coating Systems used with the Nasahi External Wall System must be guaranteed by the coating manufacturer, and meet the minimum performance requirements specified by Nasahi. It must have been prepared and installed in accordance with the manufacturers written instructions and technical specifications. Only projects for which a completed Nasahi Installation Compliance Certificate has been received will be eligible for the Nasahi guarantee. Blank certificates are available from our website. This guarantee applies to the performance of the system for the uses outlined in this Installation guide and excludes liability for consequential damage or losses in connection with defective cladding, other than those imposed by legislation.

Warranty

The Nasahi Panels, when installed in accordance with this guide, are warranted for a period of 15 years (from date of purchase) to be free from any defects subject to the conditions and exclusions set out in the Nasahi Warranty document available on our website. Nasahi Products are warranted to not materially degrade, corrode or breakdown during the Term of this warranty (Nasahi Warranty document).

Disclaimer

The information presented within this Installation guide is provided in good faith and, to the best of our knowledge, is accurate at the time of preparation. The provision of this information should not be interpreted as a recommendation to use any of our products in violation of patent rights or in breach of statutes or regulations. Users are advised to make their own determination as to the suitability of this information in relation to their particular project and circumstances. As the information contained within this Installation guide may be applied under conditions beyond our control, no responsibility can be accepted by Nasahi, or its staff for any losses or damage caused by any person acting or refraining from action as a result of misuse of this information.

